

Series TY-B — 5.6 and 8.0 K-factor Conventional (Old Style) Sprinklers Standard Response

General Description

The Series TY-B, 5.6 and 8.0 K-factor, Conventional Sprinklers described in this data sheet are standard response - standard coverage, decorative 5 mm glass bulb type spray sprinklers. These sprinklers are intended to be installed either pendent or upright, and in either position, they produce a spherical water discharge pattern with approximately 50% of the discharge directed upwards and approximately 50% of the discharge directed downwards.

Conventional sprinklers are generally used with Ordinary and Extra High Hazard Class Systems, as defined by the automatic sprinkler system installation rules of the country and authority having jurisdiction. The NATIONAL FIRE PROTECTION ASSOCIATION (NFPA) permits the use of "Old Style Sprinklers" where special construction features require a unique water distribution; for the protection of fur vaults; or, the replacement of similar sprinklers that had been installed prior to 1955.

Corrosion resistant coatings, where applicable, are utilized to extend the life of copper alloy sprinklers beyond that which would otherwise be obtained when exposed to corrosive atmospheres. Although corrosion resistant coated sprinklers have passed the standard corrosion tests of the applicable approval agencies, the testing is not representative of all possible cor-

rosive atmospheres. Consequently, it is recommended that the end user be consulted with respect to the suitability of these coatings for any given corrosive environment. The effects of ambient temperature, concentration of chemicals, and gas/chemical velocity, should be considered, as a minimum, along with the corrosive nature of the chemical to which the sprinklers will be exposed.

NOTICE

The Series TY-B Sprinklers described herein must be installed and maintained in compliance with this document, as well as with the applicable standards of the NATIONAL FIRE PROTECTION ASSOCIATION, in addition to the standards of any other authorities having jurisdiction. Failure to do so may impair the performance of these devices.

The owner is responsible for maintaining their fire protection system and devices in proper operating condition. Contact the installing contractor or product manufacturer with any questions.

Sprinkler Identification Numbers (SINs)

TY3651. 5.6K, 1/2 in. NPT
TY4651. 8.0K, 3/4 in. NPT

Technical Data

Approvals

UL and C-UL Listed.
LPCB, VdS, and NYC Approved.

(Refer to Table A for complete approval information including corrosion resistant status.)

Maximum Working Pressure

175 psi (12,1 bar)

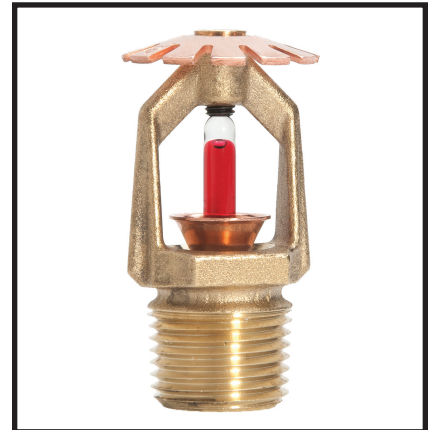

Discharge Coefficient

K = 5.6 GPM/psi^{1/2} (80,6 LPM/bar^{1/2})
K = 8.0 GPM/psi^{1/2} (115,2 LPM/bar^{1/2})

Temperature Ratings

Refer to Table A

Finishes

Sprinkler: Refer to Table B

Physical Characteristics

Frame	Bronze
Button	Brass/Copper
Sealing Assembly	Beryllium Nickel w/TEFLON
Bulb	Glass
Compression Screw	Bronze
Deflector	Copper

Operation

The glass bulb contains a fluid which expands when exposed to heat. When the rated temperature is reached, the fluid expands sufficiently to shatter the glass bulb, allowing the sprinkler to activate and water to flow.

IMPORTANT

Refer to Technical Data Sheet TFP2300 for warnings pertaining to regulatory and health information.

Always refer to Technical Data Sheet TFP700 for the "INSTALLER WARNING" that provides cautions with respect to handling and installation of sprinkler systems and components. Improper handling and installation can permanently damage a sprinkler system or its components and cause the sprinkler to fail to operate in a fire situation or cause it to operate prematurely.

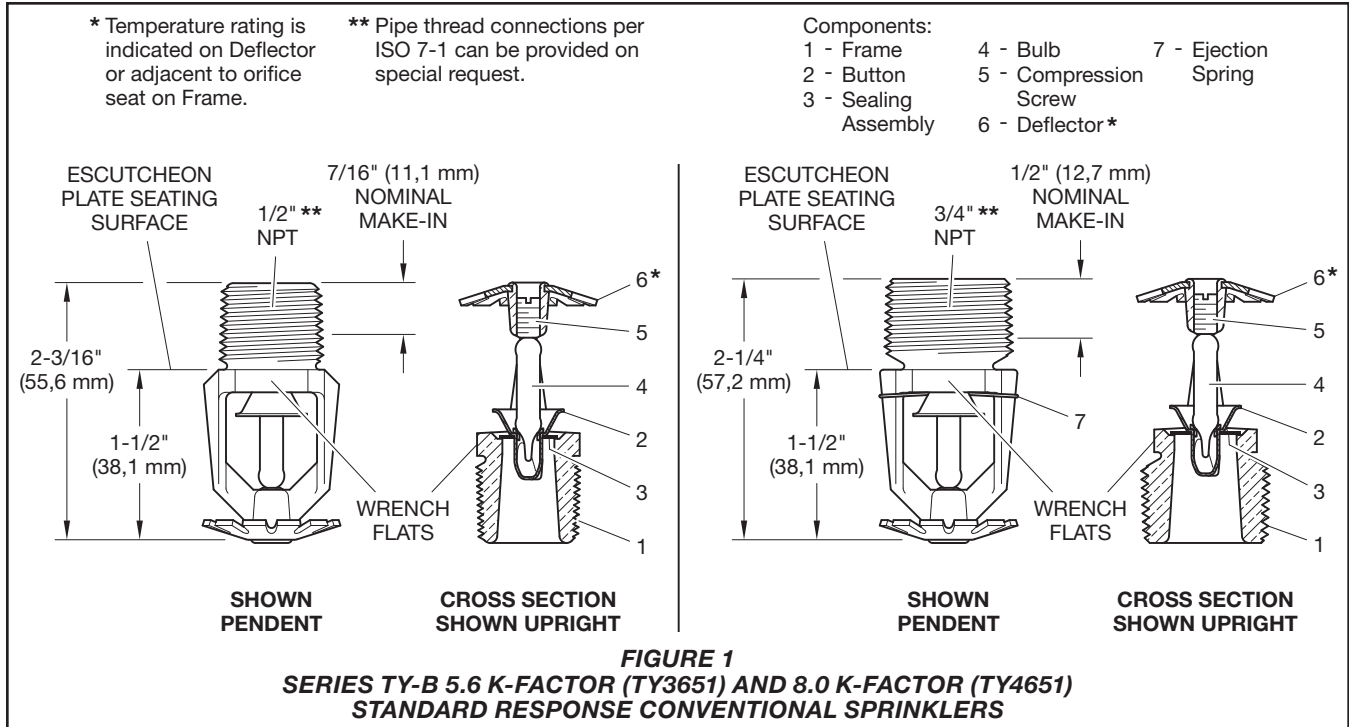

Design Criteria

The Series TY-B Conventional Sprinklers are intended for fire protection systems designed in accordance with the standard installation rules recognized by the applicable Listing or Approval agency (e.g., UL Listing is based on NFPA 13 requirements). The Series TY-B Conventional Sprinklers are only for non-recessed applications.

Installation

The Series TY-B Sprinklers must be installed in accordance with this section.

General Instructions

Do not install any bulb type sprinkler if the bulb is cracked or there is a loss of liquid from the bulb. With the sprinkler held horizontally, a small air bubble should be present. The diameter of the air bubble is approximately 1/16 in. (1,6 mm) for the 135°F (57°C) to 3/32 in. (2,4 mm) for the 360°F (182°C) temperature ratings.

A leak tight 1/2 in. NPT sprinkler joint should be obtained with a torque of 7 to 14 lb-ft (9,5 to 19,0 N·m). A leak tight 3/4 in. NPT sprinkler joint should be obtained with a torque of 10 to 20 lb-ft (13,4 to 26,8 N·m). Higher levels of torque may distort the sprinkler inlet and cause leakage or impairment of the sprinkler.

Step 1. With pipe thread sealant applied to the pipe threads, hand tighten the sprinkler into the sprinkler fitting.

Step 2. Tighten the sprinkler into the sprinkler fitting using only the W-Type 6 Sprinkler Wrench (Ref. Figure 2), except that an 8 in. or 10 in. adjustable Crescent wrench is to be used for wax coated sprinklers. With reference to Figure 1, the W-Type 6 Sprinkler Wrench or the Crescent wrench, as applicable, is to be applied to the wrench flats.

When installing wax coated sprinklers with the adjustable Crescent wrench, additional care needs to be exercised to prevent damage to the wax coating on the sprinkler wrench flats or frame arms and, consequently, exposure of bare metal to the corrosive environment. The jaws of the wrench should be opened sufficiently wide to pass over the wrench flats without damaging the wax coating. Before wrench tightening the sprinkler, the jaws of the wrench are to be adjusted to just contact the sprinkler wrenching flanges. After wrench tightening the sprinkler, loosen the wrench jaws before removing the wrench.

After installation, the sprinkler wrench flats and frame arms must be inspected and the wax coating retouched (repaired) whenever the coating has been damaged and bare metal is exposed. The wax coating on the wrench flats can be retouched by gently applying a heated 1/8 in. diameter steel rod to the areas of wax that

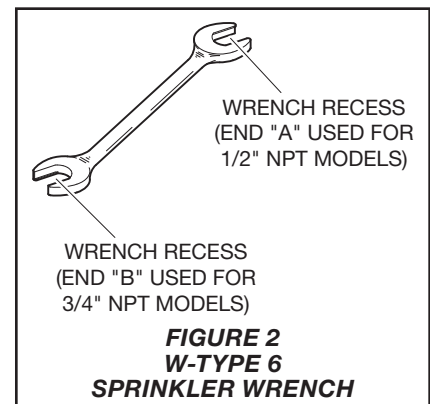

have been damaged, to smooth it back over areas where bare metal is exposed.

NOTES: Only retouching of the wax coating applied to the wrench flats and frame arms is permitted, and the retouching is to be performed only at the time of the initial sprinkler installation.

The steel rod should be heated only to the point at which it can begin to melt the wax, and appropriate precautions need to be taken, when handling the heated rod, in order to prevent the installer from being burned.

If attempts to retouch the wax coating with complete coverage are unsuccessful, additional wax can be ordered in the form of a wax stick (the end of which is color coded). Only the correct color coded wax is to be used, and retouching of wrench flats and frame arms is only permitted at the time

			SPRINKLER FINISH (See Note 6)					
TYPE	TEMP.	BULB LIQUID	NATURAL BRASS	CHROME PLATED	POLYESTER***	LEAD COATED	WAX COATED	WAX OVER LEAD COATED
5.6K Conventional (TY3651) or 8.0K Conventional (TY4651)	135°F (57°C)	Orange	1, 2, 3, 4, 5			1, 2, 4	1, 2, 4	1, 2, 4
	155°F (68°C)	Red						
	175°F (79°C)	Yellow						
	200°F (93°C)	Green					1**, 2**, 4**	1**, 2**, 4**
	286°F (141°C)	Blue					N/A	
360°F (182°C)	Mauve	N/A						

NOTES:

- Listed by Underwriters Laboratories, Inc. (UL).
 - Listed by Underwriters Laboratories, Inc. for use in Canada (C-UL).
 - Approved by the Loss Prevention Certification Board (LPCB Ref. No. 094a/05 & 007k/03).
 - Approved by the City of New York under MEA 354-01-E.
 - VdS Approved (For details contact Johnson Controls, Enschede, Netherlands, Tel. 310530428-4444/Fax 31-53-428-3377)
 - Where Polyester Coated, Lead Coated, Wax Coated, and Wax over Lead Coated Sprinklers are noted to be UL and C-UL Listed, the sprinklers are UL and C-UL Listed as Corrosion Resistant Sprinklers.
- ** 150°F (66°C) Maximum Ceiling Temperature.
 *** Frame and Deflector only.
 N/A: Not Available

TABLE A
LABORATORY LISTINGS AND APPROVALS

of initial sprinkler installation. With the steel rod heated as previously described, touch the rod to the area requiring additional wax with the rod angled downward, and then touch the wax stick to the rod approximately one-half inch away from the area requiring retouching. The wax will melt and run down onto the sprinkler.

Care and Maintenance

The Series TY-B Sprinklers must be maintained and serviced in accordance with this section

Before closing a fire protection system main control valve for maintenance work on the fire protection system that it controls, permission to shut down the affected fire protection system must be obtained from the proper authorities and all personnel who may be affected by this action must be notified.

Sprinklers that are found to be leaking or exhibiting visible signs of corrosion must be replaced.

Automatic sprinklers must never be painted, plated, coated or otherwise altered after leaving the factory. Modified sprinklers must be replaced. Sprinklers that have been exposed to corrosive products of combustion, but have not operated, should be replaced if they cannot be completely cleaned by wiping the sprinkler with a cloth or by brushing it with a soft bristle brush.

Care must be exercised to avoid damage to the sprinklers before, during, and after installation. Sprinklers damaged by dropping, striking, wrench twist/slippage, or the like, must be replaced. Also, replace any sprinkler that has a cracked bulb or that has lost liquid from its bulb. (Ref. Installation Section).

Frequent visual inspections are recommended to be initially performed for corrosion resistant coated sprinklers, after the installation has been completed, to verify the integrity of the corrosion resistant coating. Thereafter, annual inspections per NFPA 25 should suffice; however, instead of inspecting from the floor level, a random sampling of close-up visual inspections should be made, so as to better determine the exact sprinkler condition and the long term integrity of the corrosion resistant coating, as it may be affected by the corrosive conditions present.

The owner is responsible for the inspection, testing, and maintenance of their fire protection system and devices in compliance with this document, as well as with the applicable standards of the NATIONAL FIRE PROTECTION ASSOCIATION (e.g., NFPA 25), in addition to the standards of any other authorities having jurisdiction. The installing contractor or sprinkler manufacturer should be contacted relative to any questions.

It is recommended that automatic sprinkler systems be inspected, tested, and maintained by a qualified Inspection Service in accordance with local requirements and/or national codes.

Limited Warranty

For warranty terms and conditions, visit www.tyco-fire.com.

P/N 57 - XXX - X - XXX

		SIN			TEMPERATURE RATINGS	
573	5.6K CONVENTIONAL	TY3651	1	NATURAL BRASS	135	135°F (57°C)
593	8.0K CONVENTIONAL	TY4651	3	PURE WHITE (RAL9010)** POLYESTER	155	155°F (68°C)
			4	SIGNAL WHITE (RAL9003) POLYESTER	175	175°F (79°C)
			6	WAX COATED 286°F (141°C) MAX.	200	200°F (93°C)
			7	LEAD COATED	286	286°F (141°C)
			8	WAX OVER LEAD 286°F (141°C) MAX	360	360°F (182°C)
			9	CHROME PLATED	000	OPEN***

** Eastern Hemisphere sales only

*** Available only for 8.0 K-factor TY4651 for use in Deluge Systems (OPEN indicates sprinkler assembly without Glass Bulb, Button, and Sealing Assembly)

TABLE B
SERIES TY-B CONVENTIONAL SPRINKLERS
PART NUMBER SELECTION

Ordering Procedure

Contact your local distributor for availability. When placing an order, indicate the full product name and Part Number (P/N).

Sprinkler Assemblies with NPT Thread Connections

Specify: Series TY-B Conventional Sprinkler Standard Response, (specify Model/SIN), (specify K-factor), (specify) temperature rating, with (specify finish or coating), P/N (specify from Table B)

Sprinkler Wrench

Specify: W-Type 6 Sprinkler Wrench, P/N 56-000-6-387

Wax Sticks

(For retouching wrench damaged wax coating)

Specify: (specify color) color coded Wax Stick for retouching (specify temperature rating) temperature rated Series TY-B Sprinklers, P/N (specify):

Black for 135°F (57°C) 56-065-1-135
 Red for 155°F (68°C) 56-065-1-155
 Yellow for 175°F (79 °C) 56-065-1-175
 Blue for 200°F (93°C) and
 286°F (141°C) 56-065-1-286

NOTE: Each wax stick is suitable for retouching up to twenty-five sprinklers.

The wax used for 286°F (141°C) sprinklers is the same as for 200°F (93°C) sprinklers, and, therefore, the 286°F (141°C) sprinkler is limited to the same maximum ceiling temperature as the 200°F (93°C) sprinkler (i.e., 150°F (66°C)).