

## **INSTALLER WARNING!!!** **Read the following cautions before handling or installing your sprinklers.**

### **Cautions**

**IMPROPER HANDLING AND/OR INSTALLATION CAN PERMANENTLY DAMAGE A SPRINKLER AND CAUSE THE SPRINKLER TO FAIL TO OPERATE IN A FIRE SITUATION OR CAUSE IT TO OPERATE PREMATURELY.**

**ALWAYS REFER TO THE TECHNICAL DATA SHEET FOR THE SPRINKLER THAT IS TO BE INSTALLED. THE TECHNICAL DATA SHEET PROVIDES DESIGN CRITERIA RELATED TO PROPER APPLICATION OF THE SPRINKLER (INCLUDING BUT NOT LIMITED TO SUITABLE HAZARDS TO WHICH THE SPRINKLER CAN BE APPLIED, CEILING CONSTRUCTION, INSTALLATION DIMENSIONS, AND MINIMUM FLOW RATES). IMPROPER APPLICATION CAN CAUSE THE SPRINKLER TO FAIL IN A FIRE SITUATION.**

Cautions must be understood by all disciplines (for example, sprinkler fitters, designers, authorities having jurisdiction, and material handlers) involved with the installation of automatic sprinklers. Care must be exercised during installation, and the following guidelines must be followed to ensure that the sprinkler will operate properly:

- Store sprinklers properly and shield them from extreme heat. Do not store sprinklers in direct sunlight or in areas of vehicles that are subject

#### **IMPORTANT**

Refer to Technical Data Sheet TFP2300 for warnings pertaining to regulatory and health information.

Always refer to Technical Data Sheet TFP700 for the "INSTALLER WARNING" that provides cautions with respect to handling and installation of sprinkler systems and components. Improper handling and installation can permanently damage a sprinkler system or its components and cause the sprinkler to fail to operate in a fire situation or cause it to operate prematurely.

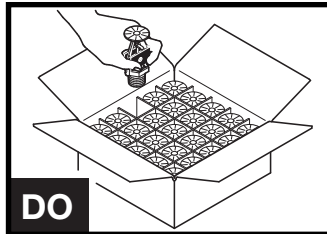

**DO** leave sprinklers in their shipping container until they are installed.

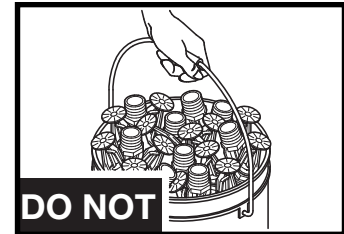

**DO NOT** dump sprinklers into container.

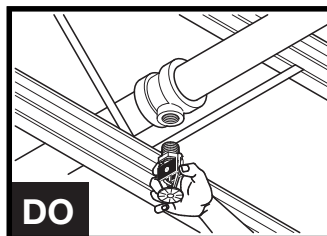

**DO** install sprinklers in sprinkler fittings after sprinkler pipe is in place.

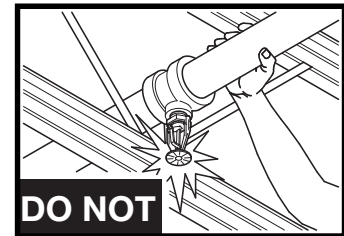

**DO NOT** slide pipe through structure with sprinklers in place.

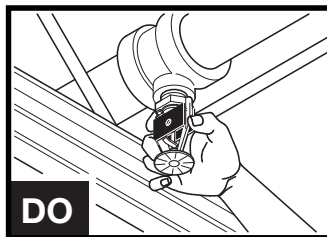

**DO** hand-start sprinklers by gently handling the sprinkler.

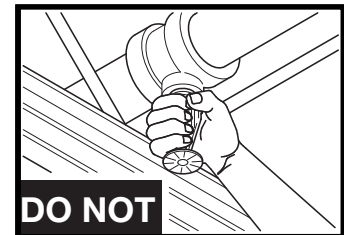

**DO NOT** install sprinklers by grasping the thermal sensing element or deflector.

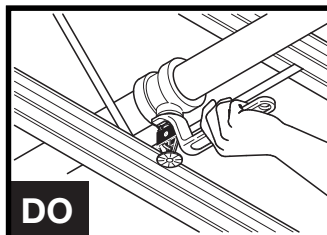

**DO** install sprinklers with the manufacturer's required sprinkler wrench.  
**DO** leave the sprinkler strap, where provided, on until the sprinkler is to be placed in service.

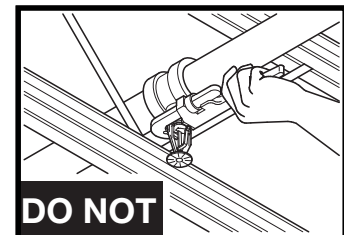

**DO NOT** use improper wrenches.  
**DO NOT** remove the sprinkler strap, where provided, until the sprinkler is to be placed in service.

to extreme temperatures. Over-heating will damage the sprinkler by weakening the thermal sensing element resulting in premature activation.

- Sprinkler cartons are specially designed to protect the sprinkler during transit. Do not empty sprinklers from their cartons into bags or buckets prior to installation, since damage to the sprinklers may result. Install the sprinklers directly from their cartons.
- Unless otherwise modified by NATIONAL FIRE PROTECTION STANDARDS (NFPA) such as NFPA 13 "Installation of Sprinkler Systems", sprinkler temperature ratings shall be as follows:

Maximum Ceiling Temperature, °F (°C)	Sprinkler Temperature Rating, °F (°C)
100 (38)	135-170 (57-77)
150 (66)	175-250 (79-107)
225 (107)	250-300 (121-149)
300 (149)	325-375 (163-191)
375 (191)	400-475 (204-246)
475 (246)	500-575 (260-302)
625 (329)	650 (343)
<b>TABLE A TEMPERATURE RATINGS</b>	

Over-heating will damage the sprinkler by weakening the thermal sensing element resulting in premature activation.

- Do not install any sprinkler that shows signs of damage. Immediately replace all sprinklers that are damaged during installation.
- Inspect glass bulb sprinklers at the time of installation to make sure that the bulb contains fluid. Inspection of the glass bulb is to be made with the sprinkler strap in place by looking through the openings of the sprinkler strap.

Any glass bulb that shows evidence of leakage or that does not have any fluid must be discarded. Do not install any bulb type sprinkler if the bulb is cracked or there is a loss of liquid from the bulb. With the sprinkler held horizontally, a small air bubble should be present. The diameter of the air bubble is approximately 1/16 inch (1,6 mm) for the 135°F (57°C) to 3/32 inch (2,4 mm) for the 360°F (182°C) temperature ratings. Loss of liquid from a bulb can cause the sprinkler to fail to activate in a

fire. Install sprinklers in fittings with the pipe 'in place'. Sliding piping through structural members with the sprinklers in place can severely damage sprinklers.

- Do not apply any thread roughening process to the sprinkler thread. Application of this effect can cause distortion of the frame, which may result in leakage or damage to the actuation mechanism.
- When starting the thread of a sprinkler, do not over-tighten by hand. Excessive tightening by hand can cause damage to the thermal sensing element without knowledge to the installer.
- Always wrench tighten the sprinklers with the sprinkler wrench specified for use with the specific sprinkler being installed. Using the wrong wrench can damage the sprinkler.
- Apply sprinkler wrenches to the proper sprinkler wrench boss/flats only. Do not allow the sprinkler wrench to slip during the wrench tightening procedure. Wrenching the sprinkler frame arms, deflector, or thermal sensing element, and/or wrench slippage, will severely damage the sprinkler.
- Do not over-tighten (maximum torque is as follows: 1/2" NPT/14 ft.-lbs.; 3/4" NPT/20 ft.-lbs.; 1" NPT/30 ft.-lbs.). Over-tightening can distort the sprinkler inlet causing leakage or inability of the sprinkler to operate properly.
- Do not attempt to make-up for insufficient adjustment in the escutcheon plate by under- or over-tightening the sprinkler. Over-tightening can distort the sprinkler inlet causing leakage or inability of the sprinkler to operate properly. Under-tightening can result in pipe thread leakage. Relocate the position of the sprinkler, as necessary, to facilitate the adjustment provided by the escutcheon.
- Do not remove protective devices (for example, sprinkler straps or protective caps for concealed type sprinklers) until the water supply, either temporary or permanent, is made available to the sprinklers for purposes of fire protection. Failure to maintain the protective devices where provided may allow damage to occur to the thermal sensing element with increasing risk of the sprinkler failing to activate in a fire or causing the sprinkler to activate prematurely.

**Note:** For upright sprinklers and sprinklers installed more than 10 ft. (3,1 m) above the floor, protective devices (for example, sprinkler straps or protec-

tive caps for concealed type sprinklers) are permitted to be removed from the sprinklers immediately following their installation. (Where installation of mechanical services or other construction work is expected to take place following the installation of sprinklers, consideration should be given to leaving protective devices in place until such time as the water supply is made available to the sprinklers for purposes of fire protection.)

- After a protective device (for example, sprinkler straps or protective caps for concealed type sprinklers) is removed, inspect glass bulb sprinklers to make sure that the bulbs contain fluid, and inspect fusible solder type sprinklers for damage to the fusible element and associated link assembly parts.

Any sprinkler having a glass bulb that shows evidence of leakage or that does not have any fluid must be replaced, and any sprinkler that shows evidence of damage to the fusible element and associated link assembly parts must be replaced.

- Sprinklers cannot operate properly with protective devices in place (for example, sprinkler straps or protective caps for concealed type sprinklers). As applicable, refer to the "Sprinkler Strap Instructions" provided in this data sheet.
- Sprinklers that are found to be leaking or exhibiting visible signs of corrosion must be replaced. Leakage and/or corrosion may cause the sprinkler to fail to activate in a fire, and corrosion may cause the sprinkler to activate prematurely.
- Automatic sprinklers (including cover plates of concealed type sprinklers) must never be painted, plated, coated or otherwise altered after leaving the factory. Painted, coated, or otherwise altered sprinklers may interfere with the sprinkler's ability to operate in a fire. Modified sprinklers must be replaced.
- After a fire, bulb type sprinklers that have been exposed to corrosive products of combustion, but have not operated, should be replaced if they cannot be completely cleaned by wiping the sprinkler with a cloth or by brushing it with a soft bristle brush.
- After a fire, overheated solder type sprinklers must be replaced. Over-heating will damage the sprinkler by weakening the thermal sensing element resulting in premature activation.

- Care must be exercised to avoid damage to the sprinklers - before, during, and after installation. Sprinklers damaged by dropping, striking, wrench twist/slippage, or the like, must be replaced. Damaged sprinklers may cause the sprinkler to fail to activate in a fire or cause the sprinkler to activate prematurely.
- Treatment of water to counter the effects of microbiologically influenced corrosion must take into consideration compatibility with the materials of construction used for all of the sprinkler system components. Otherwise leakage and/or deterioration of components with resulting system failure may result.
- Sprinklers, unless otherwise protected by corrosion resistant coating or materials of construction, must be installed in a noncorrosive environment (internal and external). The improper use of corrosive agents such as flux, other products that contain chloride ions, whether applied internally or externally to the sprinkler system, may result in corrosion of the sprinkler head, or stress corrosion cracking, which in turn may cause the sprinklers heads to develop leaks, operate unexpectedly, or not operate properly.
- Corrosion resistant coatings or materials of construction, where applicable, are utilized to extend the life of copper alloy sprinklers beyond that which would otherwise be obtained when exposed to corrosive atmospheres. Although corrosion resistant coated sprinklers have passed the standard corrosion tests of the applicable approval agencies, the testing is not representative of all possible corrosive atmospheres. Consequently, it is recommended that the end user be consulted with respect to the suitability of these coatings for any given corrosive environment. The effects of ambient temperature, concentration of chemicals, and gas/chemical velocity, should be considered, as a minimum, along with the corrosive nature of the chemical to which the sprinklers will be exposed. Incorrect corrosion resistant coating or materials of construction may cause the sprinklers to develop leaks, operate unexpectedly, or not operate properly.
- Any time copper piping is used in any part of a fire sprinkler system, the copper piping must be installed in conformance with all applicable standards and requirements for copper piping, including: NFPA 13, 13D, 13R and 25, ASTM B813, ASTM B828, and Copper Development

### SPRINKLER STRAP INSTRUCTIONS (PROTECTIVE DEVICE)

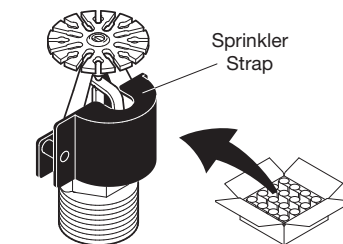
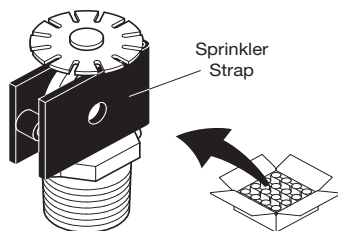

- Sprinkler Straps are factory installed on all bulb type sprinklers and selected fusible solder type sprinklers prior to shipping; therefore, the Sprinkler Straps, as applicable, will be in place when the sprinklers are removed from their shipping container.

- Hand-start and then wrench-tighten each sprinkler with the Sprinkler Strap in place. The sprinkler may be hand-started by holding onto the Sprinkler Strap. Each sprinkler equipped with a Sprinkler Strap is designed to be installed with the wrenches designated in the "Product Packing Sheet".

- Do not remove the Sprinkler Strap until the sprinkler is completely installed (that is, sprinkler is to be placed in service).

- **IMPORTANT: SPRINKLER CANNOT OPERATE PROPERLY WITH THE SPRINKLER STRAP IN PLACE.**

- Remove the Sprinkler Strap by hand and discard. The Sprinkler Strap can be discarded as a plastic commodity (High Density Polyethylene Recycling Category 2) in conformance with local regulations.

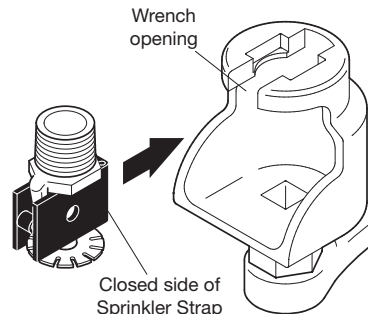
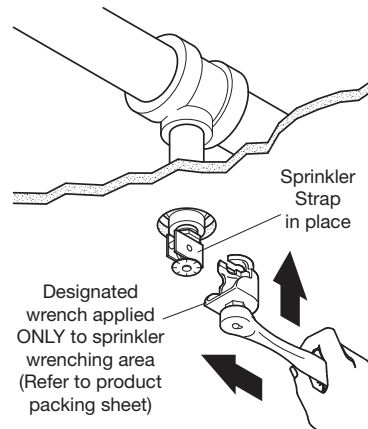

When applying recessed sprinkler wrenches, insert closed side of Sprinkler Strap into wrench opening first

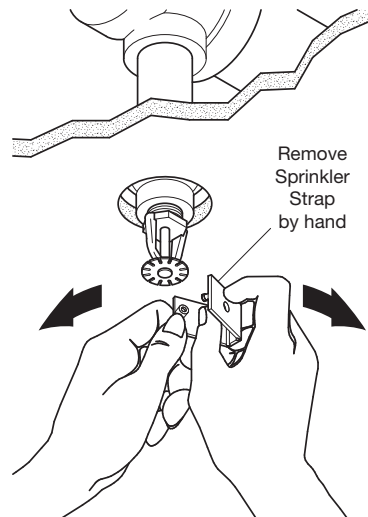

- Association (CDA). Any soldering in any part of a sprinkler system, either internally or externally, must be done with use of only an ASTM B 813 approved flux. Residual flux must be thoroughly REMOVED from both the interior and exterior surfaces of the piping before installing the sprinkler heads. The use of improper flux, or the failure to thoroughly remove proper flux, may result in corrosion of the sprinkler head or stress cracking, which in turn may cause the sprinklers heads to develop leaks, operate unexpectedly, or not operate properly.
- Do not allow solvent cement from CPVC piping installation to get into the bore of the sprinkler. Dried solvent cement can negatively affect the operation of the sprinkler by preventing the flow of water, increasing the activation pressure of the sprinkler, and causing deterioration of the seal from solvent and chlorine attack.
  - Use di-electric unions when installing sprinklers in systems that utilize both copper and steel piping as galvanic reactions can occur due to dissimilar nature of the metals causing leakage and performance concerns with the metallic components installed into the system.
  - Dry Type Sprinklers must be installed in the appropriately sized outlet or run of malleable or ductile iron threaded tee fittings that meet the dimensional requirements of ANSI B16.3 or cast iron threaded tee fittings that meet the dimensional requirements of ANSI B16.4 with the end sprinkler fitting on a branch line to be plugged. Failure to use the appropriate fitting may result in: failure of the sprinkler to properly operate due to formation of ice over the inlet Plug or binding of the inlet Plug; or, insufficient engagement of the inlet pipe threads with consequent leakage.
  - Branch, cross, and feedmain piping connected to Dry Type Sprinklers and subject to freezing temperatures must be pitched for drainage in accordance with the minimum requirements of the National Fire Protection Association for dry pipe sprinkler systems. Failure to appropriately pitch the system piping for drainage can result in ice formation at the Dry Type Sprinkler Inlet that may cause the sprinkler to fail to activate in a fire or cause the sprinkler to activate prematurely.
  - When Dry Type Sprinklers are to be used in wet pipe sprinkler systems protecting areas subject to freezing temperatures (e.g., sprinkler drops into freezers), consideration must be given to the appropriate length of the sprinkler that will prevent freezing of the water in the connecting pipes due to conduction. When the temperature surrounding the wet pipe sprinkler system is maintained at a minimum temperature of 40°F (4°C), the following are the minimum recommended lengths between the face of the sprinkler fitting and the outside surface of the protected area (that is, lengths exposed to a minimum ambient temperature of 40°F (4°C): 12 inches (300 mm) when the temperature within the protected area is -20°F (-29°C); 18 inches (450 mm) when the temperature within the protected area is -40°F (-40°C); and 24 inches (600 mm) when the temperature within the protected area is -60°F (-51°C). For protected area temperatures between those given above, the minimum recommended length from the face of the fitting to the outside of the protected area may be determined by interpolating between the indicated values. Failure to provide sufficient length may cause the sprinkler to fail to activate in a fire or cause the sprinkler to activate prematurely.
  - When Dry Type Sprinklers penetrate a ceiling or wall into an area subject to freezing, the clearance space around the Sprinkler Casing must be completely sealed in order to prevent the leakage of moist air into the freezing area which might result in the formation of condensate around the Frame, Deflector, Bulb Seat, or Bulb. Failure to prevent the formation of condensate could result in the build-up of ice around the releasing components. This could result in inadvertent operation of the sprinkler or impaired operation due to reduced thermal sensitivity.
  - For additional information on the use of sprinklers, refer to the "Product Packaging Sheet" that is enclosed separately.